



RA · RA-CLEAN



ST



SS

型式	Type	本體			取手套	
		材質	處理	顏色	材質	顏色
工業型	RA	鋁合金	陽極	銀·黑	-	-
	ST	鋼	鍍鉻	-	-	-
	SS	鋼	鍍鉻	灰	橡膠	黑
易清潔型	RA-CLEAN	鋁合金	塗裝	白	-	-

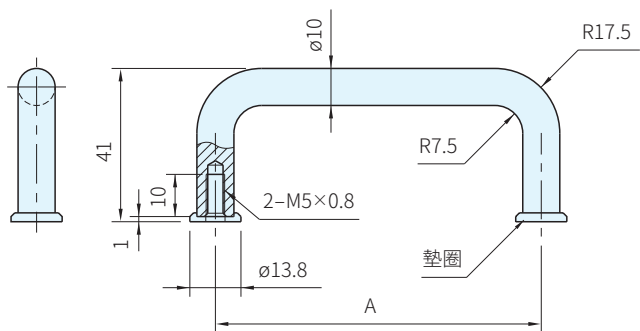

RA · RA-CLEAN

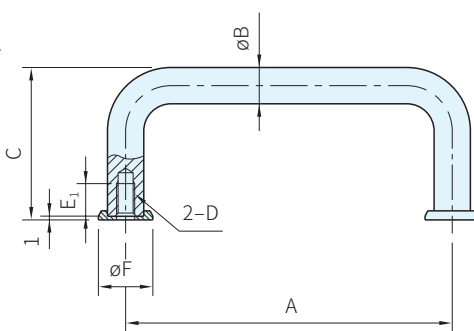

ST

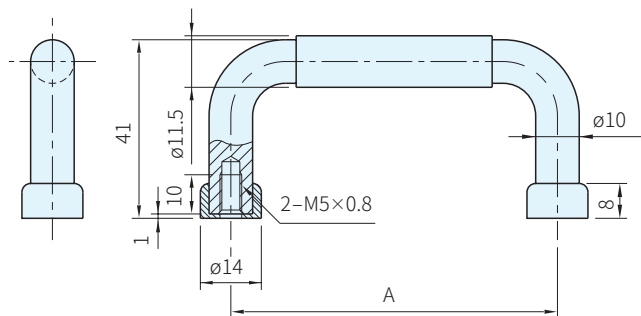

SS

銀色		黑色		白色(易清潔型)		A	容許荷重 N	質量 g
品號	庫存	品號	庫存	品號	庫存			
RA-10.055.01	·	RA-10.055.04	·	RA-10.055.9002	·	55	500	27
RA-10.088.01	·	RA-10.088.04	·	RA-10.088.9002	·	88		29
RA-10.100.01	·	RA-10.100.04	·	RA-10.100.9002	·	100		32
RA-10.120.01	·	RA-10.120.04	·	RA-10.120.9002	·	120		37
RA-10.180.01	·	RA-10.180.04	·	RA-10.180.9002	·	180		54
RA-10.200.01	·	RA-10.200.04	·	RA-10.200.9002	·	200		58
RA-10.235.01	·	RA-10.235.04	·	RA-10.235.9002	·	235		67
RA-10.250.01	·	RA-10.250.04	·	RA-10.250.9002	·	250		70

墊圈(銀色) 品號	庫存	墊圈(黑色) 品號	庫存
RA-10.000.01	·	RA-10.000.04	·

品號	A	B	C	D	E1	F	容許荷重 N	質量 g	庫存
ST-05.032.22	32	5	21	M3×0.5	6	8.0	1000	8	·
ST-05.055.22	55		25					13	·
ST-05.088.22	88		28					18	·
ST-08.032.22	32	8	33	M4×0.7	8	12.5		38	·
ST-08.055.22	55							50	·
ST-08.088.22	88							65	·
ST-08.120.22	120							67	·
ST-10.055.22	55	10	41	M5×0.8	10	15.0		87	·
ST-10.088.22	88							94	·
ST-10.100.22	100							105	·
ST-10.120.22	120						142	·	
ST-10.180.22	180						154	·	
ST-10.200.22	200						184	·	
ST-10.250.22	250								

品號	A	容許荷重 N	質量 g	庫存
SS-10.055.28	55	1000	75	·
SS-10.088.28	88		97	·
SS-10.100.28	100		105	·
SS-10.120.28	120		118	·
SS-10.180.28	180		157	·
SS-10.200.28	200		170	·
SS-10.250.28	250		203	·

WA) 注意

- RA的墊圈必須另外購買
- 1N = 0.101972kgf

訂貨： 交期：

RA-10.055.01